

Invacare® Comet
SERVICE MANUAL



Edition: 01.08.11



Yes, you can.®

These instructions contain information about:

Testing work

Repair Instructions

This manual is part of the instructions for use.

Service addresses

A	Invacare Austria GmbH	☎:	+43 6232 5 53 50
	Herzog Odilostrasse 101	Fax:	+43 6232 5 53 54
	A-5310 Mondsee	@:	info@invacare-austria.com
	Austria	WWW:	www.invacare.at

B	Invacare n.v.	☎:	+32 (0)50 83 10 10
	Autobaan 22	Fax:	+32 (0)50 83 10 11
L	B-8210 Loppem (Brugge)	@:	belgium@invacare.com
	Belgium	WWW:	www.invacare.be

CH	Invacare AG	☎:	+41 (0)61487 70 80
	Benkenstraße 260	Fax:	+41 (0)61487 70 81
	CH-4108 Witterswil	@:	switzerland@invacare.com
	Switzerland	WWW:	www.invacare.ch

D	Invacare Aquatec GmbH	☎	+49 (0)7562 70 00
	Alemannenstraße 10	Fax	+49 (0)7562 7 00 66
	88316 Isny	@:	info@invacare-aquatec.com
	Deutschland	WWW:	www.invacare-aquatec.de

DK	Invacare A/S	☎ (Kundeservice):	+45 (0)36 90 00 00
	Sdr. Ringvej 37	Fax (Kundeservice):	+45 (0)36 90 00 01
	DK-2605 Brøndby	@:	denmark@invacare.com
	Danmark	WWW:	www.invacare.dk

E	Invacare® SA	☎:	+34 (0)972 49 32 00
	c/ Areny s/n	Fax:	+34 (0)972 49 32 20
	Polígon Industrial de Celrà	@:	contactsp@invacare.com
	E-17460 Celrà (Girona)	WWW:	www.invacare.es
ESPAÑA			

F	Invacare® Poirier SAS	☎:	+33 (0)247 62 64 66
	Route de St Roch	Fax:	+33 (0)247 42 12 24
	F-37230 Fondettes	@:	contactfr@invacare.com
	France	WWW:	www.invacare.fr

GB	Invacare® Ltd Pencoed Technology Park Pencoed Bridgend CF35 5HZ United Kingdom	☎ (Customer services): +44 (0)1656 77 62 22 Fax (Customer services): +44 (0)1656 77 62 20 @: uk@invacare.com WWW: www.invacare.co.uk
I	Invacare Mecc San s.r.l. Via dei Pini, 62 I - 36016 Thiene (VI) Italia	☎: +39 0445 38 00 59 Fax: +39 0445 38 00 34 @: italia@invacare.com WWW: www.invacare.it
IE	Invacare Ireland Ltd. Unit 5 Seatown Business Campus Seatown Rd, Swords County Dublin Ireland	☎: +353 18 10 70 84 Fax: +353 18 10 70 85 @: ireland@invacare.com WWW: www.invacare.ie
N	Invacare® AS Grensvesvingen 9 Postboks 6230 Etterstad N-0603 Oslo Norge	☎ (Kundeservice): +47 (0)22 57 95 00 Fax (Kundeservice): +47 (0)22 57 95 01 @: norway@invacare.com @: island@invacare.com WWW: www.invacare.no
NL	Invacare® B.V. Celsiusstraat 46 NL-6716 BZ Ede Nederland	☎: +31 (0)318 69 57 57 Fax: +31 (0)318 69 57 58 @: nederland@invacare.com @: csede@invacare.com WWW: www.invacare.nl
P	Invacare Lda Rua Estrada Velha, 949 P-4465-784 Leça do Balio Portugal	☎: +351 225 10 59 46 ☎: +351 225 10 59 47 Fax: +351 225 10 57 39 @: portugal@invacare.com WWW: www.invacare.pt

S	Återförsäljare:	☎ (Kundtjänst):	+46 (0)8 761 70 90
	Invacare® AB	Fax (Kundtjänst):	+46 (0)8 761 81 08
FIN	Fagerstagatan 9	@:	sweden@invacare.com
	S-163 91 Spånga	@:	finland@invacare.com
	Sverige	WWW:	www.invacare.se

Tillverkare:	MÖLNDAL
Invacare® Deutschland GmbH	☎: +46 (0)31 86 36 00
Kleiststraße 49	Fax: +46 (0)31 86 36 06
D-32457 Porta Westfalica	@: ginvacare@invacare.com
Deutschland	

LANDSKRONA
☎: +46 (0)418 2 85 40
Fax: +46 (0)418 1 80 89
@: linvacare@invacare.com

OSKARSHAMN
☎: +46 (0)491 1 01 40
Fax: +46 (0)491 1 01 80
@: oinvacare@invacare.com

Eastern european countries	European Distributor Organisation (EDO)	☎	+49 (0)5731 75 45 40
	Kleiststraße 49	Fax	+49 (0)5731 75 45 41
	D-32457 Porta Westfalica	@:	edo@invacare.com
	Deutschland	WWW:	www.invacare.de

Table of Contents

Chapter	Page
1 INTRODUCTION	7
1.1 General information	7
1.2 Notes on transport	7
1.3 Definition and representation of information and safety information in this manual	8
1.4 Hazard symbols and symbols used	9
1.5 Images in this manual	10
2 SAFETY AND FITTING INSTRUCTIONS	11
2.1 Before any inspection or repair work	11
2.2 Personal safety equipment	11
2.3 General safety information and information about fitting / removal	11
3 TIGHTENING TORQUES	13
4 OVERVIEW ELECTRONIC MODULES	14
5 SERVICE PLAN (1X ANNUALLY)	15
6 OPERATIONAL FAULTS	17
6.1 Operational faults	17
6.1.1 Drive fault diagnosis	17
6.2 Error Codes and Diagnostic Codes	18
7 REPAIR WORK	20
7.1 General warning information on installation work	20
7.2 Replacing the drive motor	20
7.3 Replacing wheel suspension	24
7.4 Replacing shock absorber	26
7.5 Replacing front axle	28
7.6 Replacing steering column/fork 3-wheel	30
7.7 Replacing brakes	34

7.8	Replacing brake cable	37
7.9	Replacing lifter/lifter electronic	38
7.10	Replacing steering linkage/steering rod	40
7.11	Replacing the seat suspension / spring	42
7.12	Replacing operating console	44
7.13	Replacing bend speed reducer	46
7.14	Replacing the potentiometer	48
7.15	Replacing front headlight (lamp)	51
7.16	Replacing the front direction indicators	53
7.17	Replacing centre brake light	54
7.18	Replacing rear lights/direction indicators	56
7.19	Replacing the electronic module	58
7.20	Updating software	62

1 Introduction

1.1 General information

- Service and maintenance work must be carried out taking this service manual into account.
- It is imperative that you observe safety information.
- Information about operation or about general maintenance and care work on the mobility aid should be taken from the operating manual.
- You can find information about ordering spare parts in the spare parts catalogue.
- Only use original Invacare® spare parts. The guarantee will become invalid if other spare parts are used!
- We reserve the right to make any alterations on the grounds of technical improvements.
- The mobility aid may only be maintained and overhauled by qualified personnel.
- The minimum requirement for service technicians is suitable training, such as in the cycle or orthopaedic mechanics fields, or sufficiently long-term job experience.
 - Experience in the use of electrical measuring equipment (multimeters) is also a requirement.
 - Special Invacare® training is recommended.
- Alterations to the mobility aid which occur as a result of incorrectly or improperly executed maintenance or overhaul work lead to the exclusion of all liability on the side of INVACARE.
- If you have any problems or questions please contact Invacare® Service.

1.2 Notes on transport

- If the mobility aid has to be shipped back to the manufacturer for major repairs, you should always use the original packaging for transport.
- Please attach a precise description of the fault.

1.3 Definition and representation of information and safety information in this manual

Different types of information and signal words are used throughout this manual.



HAZARD!

The signal word "HAZARD!" refers to immediate hazards.

- *The following lines in italics refer to actions which serve to avoid such hazards.*
-



WARNING!

The signal word "WARNING!" refers to possibly-occurring hazards which can lead to death or serious injuries if they are not avoided.

- *The following lines in italics refer to actions which serve to avoid such hazards.*
-



ATTENTION!

The signal word "ATTENTION!" refers to possibly-occurring hazards which can lead to minor injuries and/or material damage if they are not avoided.

- *The following lines in italics refer to actions which serve to avoid such hazards.*
-



CAUTION!

The signal word "CAUTION!" refers to hazards which could lead to material damage if they are not avoided.

- *The following lines in italics refer to actions which serve to avoid such hazards.*
-



Note

The signal word "Note" is used to denote general information which simplifies the handling of your product and refers to special functions.

1.4 Hazard symbols and symbols used

Different types of hazard symbols and symbols are used throughout this manual.



General hazards

This symbol warns you of general hazards!

- Always follow the instructions to avoid injury to the user or damage to the product!



BURN HAZARD!

This symbol warns you of the danger of chemical burns, for example due to the discharge of battery acids!

- Always follow the instructions to avoid injury to the user or damage to the product!



DANGER OF CRUSHING!

This symbol warns you of crushing hazards due to inattentive working with heavy components.

- Always follow the instructions to avoid injury to the user or damage to the product!



EXPLOSION HAZARD!

This symbol warns you of an explosion hazard, which can be caused by excessive tyre pressure in a pneumatic tyre.

- Always follow the instructions to avoid injury to the user or damage to the product!



Wear safety shoes

The symbol refers to the requirement for wearing safety shoes.

- Wear standardised safety shoes during all work.



Wear eye protection

This symbol refers to the requirement for wearing eye protection, for example when working with batteries.

- Wear eye protection when this symbol is shown.



Wear safety gloves

This symbol refers to the requirement for wearing safety gloves, for example when working with batteries.

- Wear safety gloves when this symbol is shown.



Note

This symbol identifies general information which is intended to simplify working with your product and which refers to special functions.



Requirements:

- This symbol identifies a list of various tools, components and items which you will need in order to carry out certain work. Please do not attempt to carry out the work if you do not have the listed tools available.



Always dispose used or damaged batteries correctly

The symbol refers to information for the correct disposal of used or damaged batteries.

1.5 Images in this manual

The detailed images in this manual are given digits to identify various components. Component numbers in text and operational instructions always relate to the image directly above.

2 Safety and fitting instructions

These safety instructions are intended to prevent accidents at work, and it is imperative that they are observed.

2.1 Before any inspection or repair work

- Read and observe this repair manual and the associated operating manual!
- Observe the minimum requirements for carrying out the work (see chapter entitled „General information“!)

2.2 Personal safety equipment



Safety shoes

The mobility device, and some of its components, are very heavy. These parts can result in injuries to the feet if they are allowed to drop.

- *Wear standardised safety shoes during all work.*



Eye protection

It is possible that battery acid can be discharged when working on defective batteries or when handling batteries improperly.

- *Always wear eye protection when working on any defective or possibly defective batteries.*



Safety gloves

It is possible that battery acid can be discharged when working on defective batteries or when handling batteries improperly.

- *Always wear acid-proof safety gloves when working on any defective or possibly defective batteries.*

2.3 General safety information and information about fitting / removal



WARNING: Danger of crushing!

Various components such as the drive unit, batteries, seat etc are very heavy. This results in injury hazards to your hands!

- *Please note the high weight of some components! This applies especially to the removal of drive units, batteries and the seat.*



WARNING!

Injury hazard if the vehicle starts moving unintentionally during repair work!

- *Switch the power supply off (ON/OFF key)!*
- *Engage the drive!*
- *Before raising the vehicle, secure the wheels by blocking them with wedges!*



ATTENTION!

Fire and burn hazard due to electrical short-circuit!

- *The mobility device must be completely switched off before removal of voltage-carrying components! To do this, remove the batteries.*
- *Avoid short-circuiting the contacts when carrying out measurements on voltage-carrying components!*

**CAUTION!****Danger of burns from hot surfaces on the motor!**

- *Allow the motors to cool down before commencing work on them.*

**ATTENTION!****Injury hazard and danger of damage to vehicle due to improper or incomplete maintenance work!**

- *Use only undamaged tools in good condition.*
- *Some moving parts are mounted in sockets with PTFE coating (Teflon™). Never grease these sockets!*
- *Never use "normal" nuts instead of self-locking nuts.*
- *Always use correctly-dimensioned washers and spacers*
- *When reassembling, always replace any cable ties which were cut during dismantling.*
- *After completing your work / before renewed start-up of the mobility device, check all connections for tight fitting.*
- *After completing your work / before renewed start-up of the mobility device, check all parts for correct locking.*
- *Only operate the vehicle with the approved tyre pressures (see technical data).*
- *Check all electrical components for correct function. Please note that incorrect polarity can result in damage to the electronic.*
- *Always carry out a trial run at the end of your work.*

**Note**

Mark all current settings for the mobility aid (seat, armrests, backrest etc.), and the associated cable connecting plugs, before dismantling. This makes reassembly easier.

All plugs are fitted with mechanical safety devices which prevent release of the connecting plugs during operation. To release the connecting plugs the safety devices must be pressed in. When reassembling ensure that these safety devices are correctly engaged.

**WARNING!****Any changes to the drive program can affect the driving characteristics and the tipping stability of the vehicle!**

- *Changes to the drive program may only be carried out by trained Invacare® specialist dealers!*
- *Invacare® supplies all mobility aids with a standard drive program ex-works. Invacare® can only give a warranty for safe vehicle driving behaviour - especially tipping stability - for this standard drive program!*

3 Tightening torques

The tightening torques stated in the following list are based on the thread diameter for the nuts and bolts for which no specific values have been determined. All values assume dry and de-greased threads.

Thread	M4	M5	M6	M8	M10	M12	M14	M16
Tightening torque in Nm $\pm 10\%$	3 Nm	6 Nm	10 Nm	25 Nm	49 Nm	80 Nm	120 Nm	180 Nm

**CAUTION!**

Damage can be caused to the mobility device due to improperly tightened screws, nuts or plastic connections.

- *Always tighten screws, nuts etc to the stated tightening torque.*
- *Only tighten screws or nuts which are not listed here fingertight.*

4 Overview electronic modules

Different electronic modules can be installed in the scooter. These are listed below:

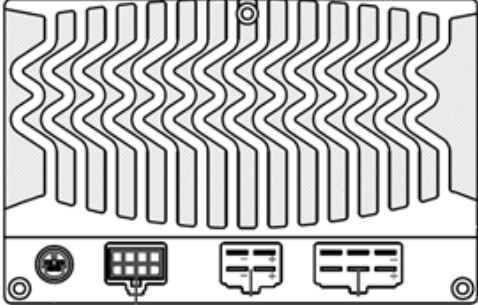
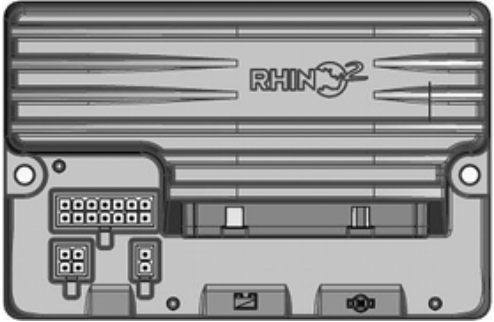
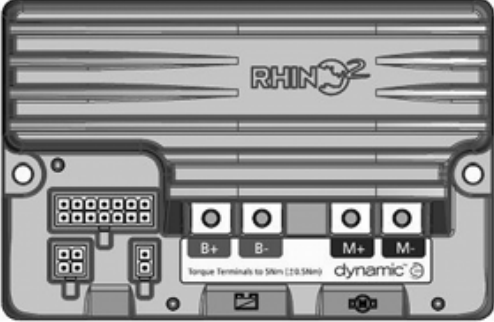
Electronic modules	Designation	Notes
	<p>Rhino1 DS112KB02 DS162KD01</p>	<p>max. current: 110 A 160 A</p>
	<p>Rhino2 DS120</p>	<p>max. current: 120 A</p>
	<p>Rhino2 DS160</p>	<p>max. current: 160 A</p>

5 Service plan (1x annually)

Component	Check	Remedy	Notes	✓
Seat:	<ul style="list-style-type: none"> Welded seams, fixings and upholstery 	<ul style="list-style-type: none"> Tighten screws, replace parts if damaged 		
	<ul style="list-style-type: none"> Seat suspension 	<ul style="list-style-type: none"> Grease the spring generously, replace parts if damaged 	See " Replacing the seat suspension / spring " on page 42	
Frames (chassis) / battery mounting	<ul style="list-style-type: none"> Check fixings, welded seams and battery mounting Check battery fixing straps 	<ul style="list-style-type: none"> Tighten screws, replace parts if damaged 		
Wheel suspension and wheels	<ul style="list-style-type: none"> Check drive wheels for tight fit 	<ul style="list-style-type: none"> Tighten hub nuts, replace if necessary 		
	<ul style="list-style-type: none"> Check steering wheels for tight fit, float and side play 	<ul style="list-style-type: none"> Adjust / replace 		
	<ul style="list-style-type: none"> Pneumatic tyre 	<ul style="list-style-type: none"> Repair or replace if damaged 	See operating manual	
	<ul style="list-style-type: none"> Check tracking and steering linkage. 	<ul style="list-style-type: none"> Tighten screws Check tracking and steering 		
Brake	<ul style="list-style-type: none"> Test brake function in pushing mode 	<ul style="list-style-type: none"> Adjust or replace brake 		
Shock absorber	<ul style="list-style-type: none"> Check shock absorber 	<ul style="list-style-type: none"> Adjust or replace shock absorber 		
Drive units, coupling mechanism	<ul style="list-style-type: none"> Check functions in drive and push modes Check clutch mechanism 	<ul style="list-style-type: none"> Replace motor if necessary Tighten screws / nuts, adjust or replace 		
Lighting	<ul style="list-style-type: none"> Check function Check cable/plug connections 	<ul style="list-style-type: none"> Replace lightbulbs or cable 		
Batteries	<ul style="list-style-type: none"> Check batteries for damage 	<ul style="list-style-type: none"> Replace batteries 	See operating manual	
	<ul style="list-style-type: none"> Check battery voltage 	<ul style="list-style-type: none"> charge batteries 	See operating manual	
	<ul style="list-style-type: none"> Check contacts and terminals 	<ul style="list-style-type: none"> Clean contacts and terminals 		

Component	Check	Remedy	Notes	✓
Drive electronic	<ul style="list-style-type: none"> • Status display flashing • Fixing • Cable, connecting plug • Drive lever function • Power supply 	<ul style="list-style-type: none"> • Evaluate blinking code • Tighten or replace fixing. • Replace cable, connecting plug. • Replace drive lever • Replace cable, connecting plug or console 		
Drive program	<ul style="list-style-type: none"> • Check drive electronic program version Newer version available? 	<ul style="list-style-type: none"> • Update software 		
Speed reduction in bends	<ul style="list-style-type: none"> • Check cable and connecting plug • Check function 	<ul style="list-style-type: none"> • Adjust or replace sensor on relay. 		

6 Operational Faults

6.1 Operational faults

Please proceed as follows if you have any problems:

- First assess the possible cause of the problem using the following table.
- Check the drive console status display. Evaluate the blink error code.
- Carry out the necessary checks and repairs as recommended in the following table.

6.1.1 Drive fault diagnosis

PROBLEM	OTHER SYMPTOMS	POSSIBLE CAUSE	SOLUTION	Documentation
Scooter will not start	Status display on operating console does not illuminate	batteries defective	<ul style="list-style-type: none"> • Replace batteries 	See operating manual
		completely discharge battery	<ul style="list-style-type: none"> • Pre-charge batteries 	
		Power supply to operating console possibly interrupted	<ul style="list-style-type: none"> • Check master fuse 	See operating instructions for main fuse position
			<ul style="list-style-type: none"> • Check cable between modules for loose connections or damage 	See " Replacing the electronic module " on page 58
	Operating console defective	<ul style="list-style-type: none"> • Replace operating console 	See " Replacing operating console " on page 44	
Operating unit status display blinking	Various causes	<ul style="list-style-type: none"> • Assess error code 	See " Error Codes and Diagnostic Codes " on page 18	

PROBLEM	OTHER SYMPTOMS	POSSIBLE CAUSE	SOLUTION	Documentation
Scooter judders in drive mode	None	Drive motor defective	<ul style="list-style-type: none"> Replace motor(s) 	See "Replacing the drive motor" on page 20
		Drive lever potentiometer defective	<ul style="list-style-type: none"> Replacing the potentiometer 	See "Replacing the potentiometer" on page 48
Batteries not being charged	None	batteries defective	<ul style="list-style-type: none"> Replace batteries 	See operating manual
	LEDs blinking on charging unit	Charging unit defective	<ul style="list-style-type: none"> Replace charging unit 	See charging unit operating manual
Scooter runs too slowly	None	Operating console defective	<ul style="list-style-type: none"> Replace operating console 	See "Replacing operating console" on page 44
		batteries defective	<ul style="list-style-type: none"> Replace batteries 	See operating manual
Scooter does not reduce speed on bends.	None	Speed reducer for bend travel not adjusted.	<ul style="list-style-type: none"> Adjust speed reducer 	
		Speed reducer defective	<ul style="list-style-type: none"> Replace speed reducer 	See "Replacing bend speed reducer" on page 46

6.2 Error Codes and Diagnostic Codes

Blink code	Fault	Consequence for the Scooter	Comments
1	Battery must be charged	Continues to drive	<ul style="list-style-type: none"> The batteries are discharged. Charge the battery as soon as possible.
2	Battery voltage too low	Stops driving	<ul style="list-style-type: none"> The batteries are depleted. Charge batteries. If you switch the Scooter off for a few minutes, the battery can often recuperate to such a stage that a short journey is still possible.
3	Battery voltage too high	Stops driving	<ul style="list-style-type: none"> The battery voltage is too high. If the battery charger is connected, disconnect it from the Scooter. The electronic system charges the batteries when running downhill and when braking. This fault is caused when the battery voltage becomes too high during this process. Switch the Scooter off and on again.

Blink code	Fault	Consequence for the Scooter	Comments
4	Power time exceeded	Stops driving	<ul style="list-style-type: none"> The maximum current was exceeded over too long a period, probably because the motor was overloaded or has been working against an immovable resistance. Switch the scooter off, wait a few minutes and then switch on again. The electronic system has determined a motor short-circuit. Check the wiring harness for short-circuit and check the motor. Contact your Invacare® dealer.
5	Brake failure	Stops driving	<ul style="list-style-type: none"> Ensure that the disconnection lever is pressed in. There is a defect in the braking coil or in the cabling. Check the magnetic brake and cabling for open or short-circuited circuitry. Contact your Invacare® dealer.
6	No neutral position when switching Scooter on.	Stops driving	<ul style="list-style-type: none"> Drive lever is not in neutral when the keyswitch was turned. Put the drive lever in neutral, turn the power off and then turn on again. It may be necessary to recalibrate the drive lever. Contact your Invacare® dealer.
7	Fault in speed potentiometer	Stops driving	<ul style="list-style-type: none"> The drive lever electronic could be faulty or incorrectly connected. Check the cabling for open or short-circuited circuitry. Potentiometer is not correctly adjusted. Put the potentiometer into the centre position.
8	Motor voltage error	Stops driving	<ul style="list-style-type: none"> The motor or its cabling is defective. Check the cabling for open or short-circuited circuitry.
9	Miscellaneous internal fault	Stops driving	<ul style="list-style-type: none"> Contact your Invacare® dealer.
10	Push/freewheel mode error	Stops driving	<ul style="list-style-type: none"> The Scooter has exceeded the permissible maximum speed during pushing or freewheeling. Switch the electronic system off and on again.

7 Repair Work

7.1 General warning information on installation work

**CAUTION!**

Risk of damage to the vehicle! Collisions can be caused if shim rings are removed from the drive wheels during installation work!

Shim rings are frequently placed between the drive shaft and the wheel hub to compensate tolerances. Collisions can be caused if these shim rings are removed and not re-installed!

- *Install all shim rings in exactly the same positions they were in before dismantling.*
-

7.2 Replacing the drive motor

**ATTENTION! Risk of accident.**

When parking the scooter on the scooters support wheels it is no longer slowed by the engine brake. The scooter can roll away out of control.

- *Place the scooter rear frame on a supporting wooden block before you remove the wheels.*
-

**ATTENTION! Risk of accident.**

Accidental rolling can lead to accidents.

- *Secure the scooter against rolling away.*
-

**NOTE:**

When disassembling, note the position of small parts such as screws and washers. Put small parts down so that they can be reassembled in the right sequence.

**NOTE:**

The plugs on the electronic module cannot be wrongly connected because all plugs have a different size and only fit in one socket.

**Requirements:**

- Open spanner, 10 mm.
 - Open spanner, 17 mm.
 - oblique pliers
 - Rubber hammer
 - Phillips screwdriver
 - Supporting wooden block
-

- Secure the scooter against rolling away.
- Place supporting wooden block under the frames at battery holder height.
- Remove the seat.
- Remove motor cover.
- Disconnect both battery plugs (1).

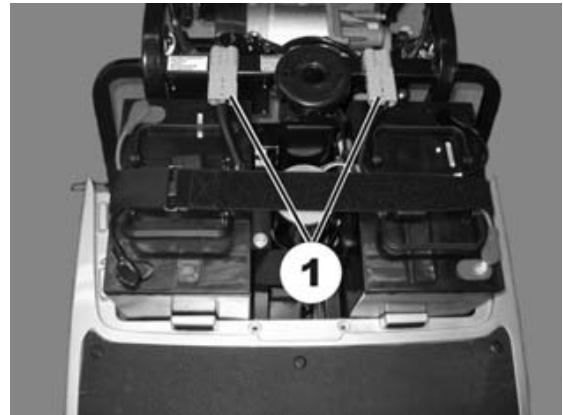

From the operating manual:

- Unscrew the rear wheel fixing bolts.
- Remove rear wheels.

- Disconnect plugs from electronic module.

Rhino1:
DS112KB02
DS162KD01

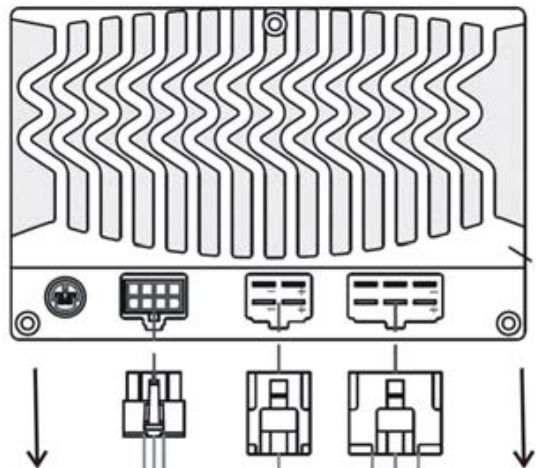

Rhino 2:
DS120:

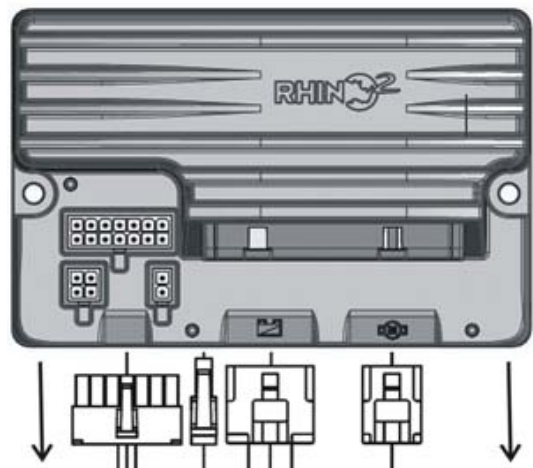

DS160

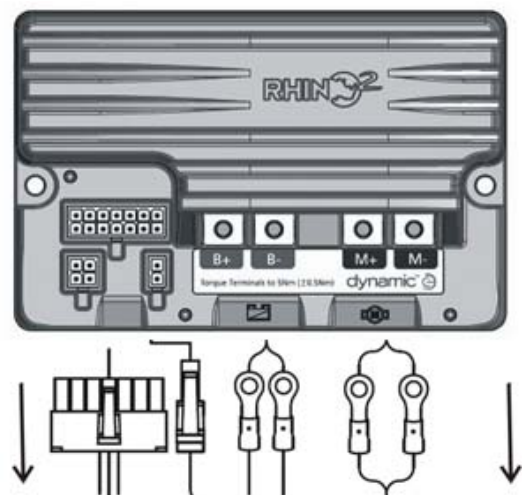

- Remove the bolt (2) on the wheel cover.
- Remove wheel cover (1).

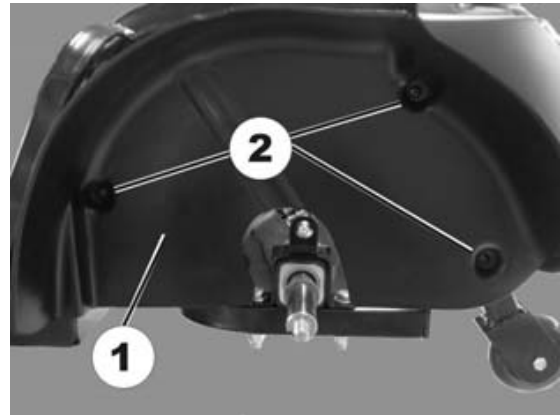

- Place a supporting block of wood under the motor link fork.
- Remove screws (1) on shock absorber (2).
- Remove screws (3) from the drive holder (4).
- Remove drive holder (4).

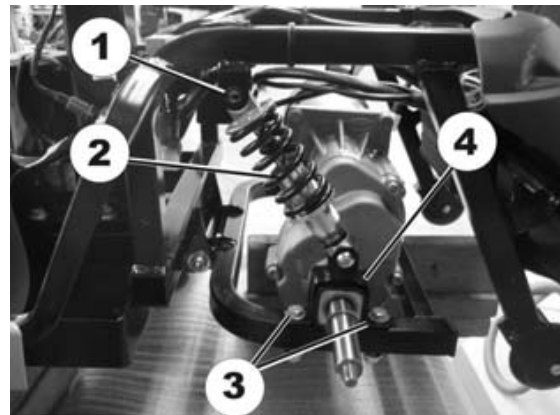

- Remove screws (1) on disengaging lever (2).
- Remove disengaging lever (2).

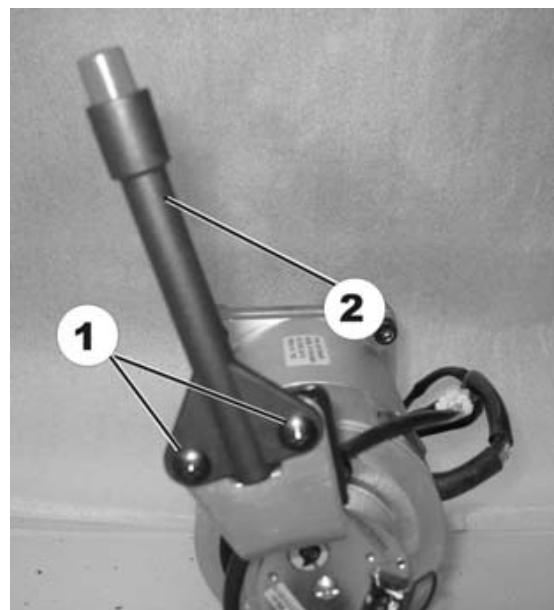

- Lifted drive out of its holder and take it out of the frames to the side.
- Replace drive unit.
- Reassembly of the drive takes place in reverse order
- Check all functions (trial run).

7.3 Replacing wheel suspension



ATTENTION! Risk of accident.

Accidental rolling can lead to accidents.

- *Secure the scooter against rolling away.*



NOTE:

When disassembling, note the position of small parts such as screws and washers. Put small parts down so that they can be reassembled in the right sequence.



Requirements:

- Open spanner, 32 mm.
- Phillips screwdriver
- Supporting wooden block

- Remove the seat.
- Remove motor cover.
- Disconnect battery cable (1).

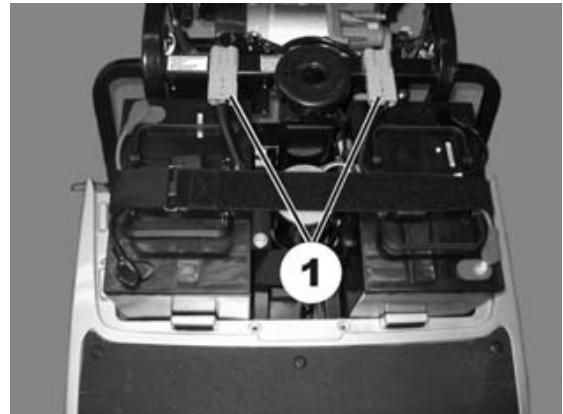

- Dismantle chassis and steering column (see chapter entitled "**Replacing steering column/fork 3-wheel**" on page 30).
- Dismantle steering linkage and steering rod (see chapter entitled "**Replacing steering linkage/steering rod**" on page 40").
- Loosen wheel suspension screw (1).
- Loosen knurled screw (2).
- Replace wheel suspension



- Reassembly takes place in the reverse order.
- Apply brake and hold, tighten wheel bolts at same time.
- Adjust tracking (see chapter entitled "**Replacing steering linkage/steering rod**" on page **40**").
- Check function (trial run).

7.4 Replacing shock absorber



ATTENTION! Risk of accident.

When parking the scooter on the scooters support wheels it is no longer slowed by the engine brake. The scooter can roll away out of control.

- Place the scooter rear frame on a supporting wooden block before you remove the wheels.



ATTENTION! Risk of accident.

Accidental rolling can lead to accidents.

- Secure the scooter against rolling away.



NOTE:

When disassembling, note the position of small parts such as screws and washers. Put small parts down so that they can be reassembled in the right sequence.



NOTE:

The drive motor needs to be removed before you can replace the left-hand shock absorber. If the right-hand shock absorber is to be replaced, you do not need to remove the drive motor.



Requirements:

- Open spanner, 10 mm.
- Open spanner, 17 mm.
- Phillips screwdriver
- 2 Allen keys 5m
- Supporting wooden block

- Remove wheel (see operating manual)
- Dismantle wheel cover (see chapter entitled "Replacing the drive motor" on page 20).

Replacing rear shock absorber:

- Remove top screw (1) on shock absorber (2).
- Remove both screws (4) from motor bracket (5).
- Remove shock absorber (2) with motor bracket (5).
- Remove bottom screw (6) on shock absorber (2).
- Replace shock absorber (2).

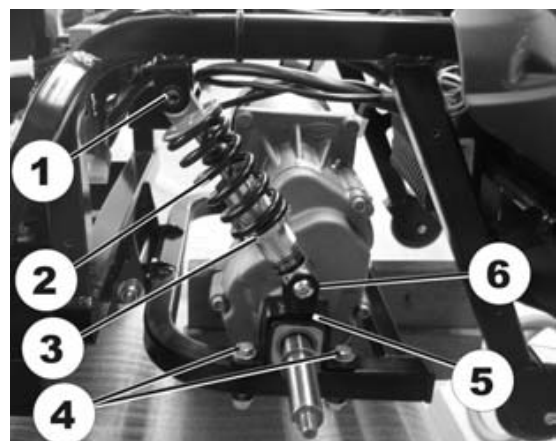

Replacing front shock absorber:

- Remove top screw (1) on shock absorber (2).
- Remove bottom screw (4) on shock absorber (2).
- Replace shock absorber (2).

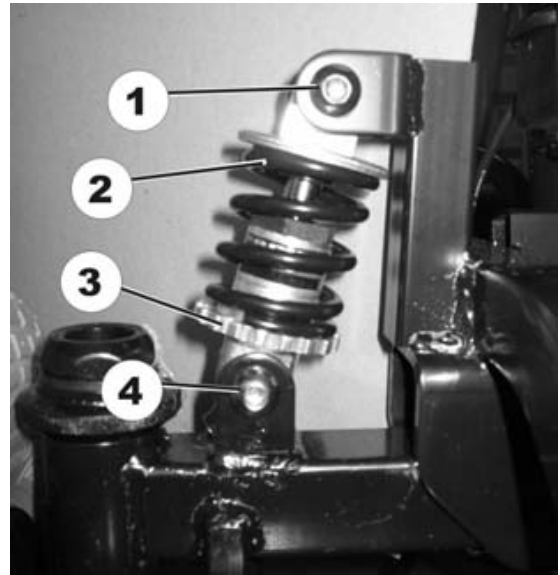

- Reassembly of the shock absorber takes place in reverse order.
- Use setting screw (3) to set the spring hardness.
- Check function (trial run).

7.5 Replacing front axle



ATTENTION! Risk of accident.

Accidental rolling can lead to accidents.

- *Secure the scooter against rolling away.*



NOTE:

When disassembling, note the position of small parts such as screws and washers. Put small parts down so that they can be reassembled in the right sequence.



NOTE:

The front axle can only be replaced on the 3-wheel version. The 4-wheel version does not have a replaceable axle.



Requirements:

- Open spanner, 17 mm.
- Open spanner, 19 mm.
- Supporting wooden block

- Place a supporting wooden block under the front part of the frame so that the front wheel is no longer touching the floor.
- Loosen axle bolts (1) simultaneously on both sides.

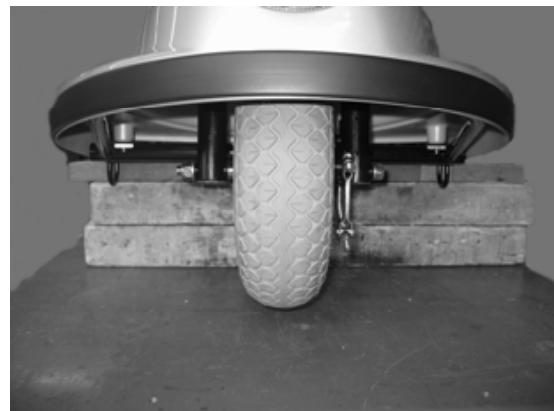

- Slacken brake cable (see chapter entitled "**Replacing brake cable**" on page 37).
- Disconnect the brake cable at the wheel (1).
- Remove screws (3) on spacer (2).
- Remove screws (6) on shock absorber (5).
- Loosen axle bolts (4) simultaneously on both sides.
- Pull front axle slowly out.

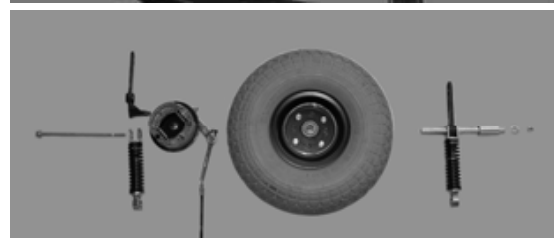
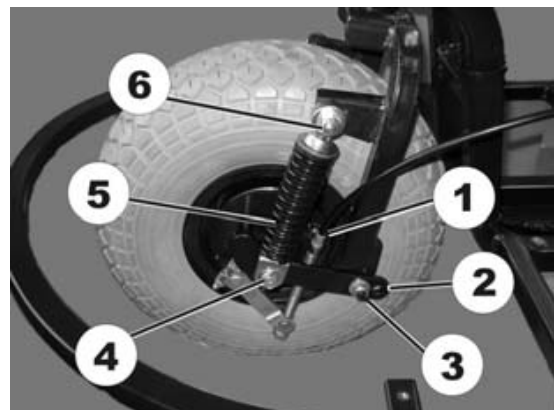

- Reassembly of the axle takes place in reverse order
- Operate brake and hold, tighten axle bolts at same time.
- Check function (trial run).

7.6 Replacing steering column/fork 3-wheel



ATTENTION! Risk of accident.

Accidental rolling can lead to accidents.

- *Secure the scooter against rolling away.*



NOTE:

When disassembling, note the position of small parts such as screws and washers. Put small parts down so that they can be reassembled in the right sequence.



Requirements:

- Open spanner, 10 mm.
- Open spanner, 17 mm.
- Open spanner, 19 mm.
- Open spanner, 32 mm.
- Phillips screwdriver
- Supporting wooden block

- Remove the seat.
- Remove motor cover.
- Separate battery cable.

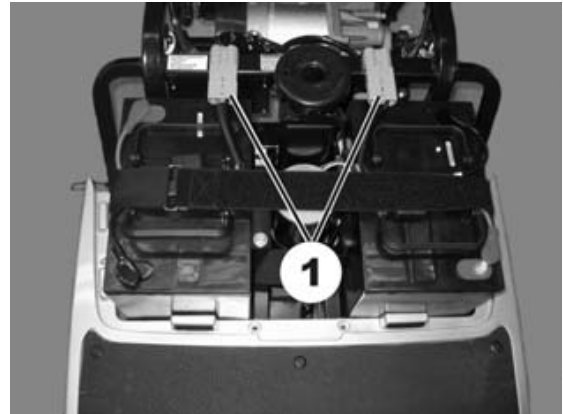

- Place a supporting wooden block under the front part of the frame so that the front wheel is no longer touching the floor.

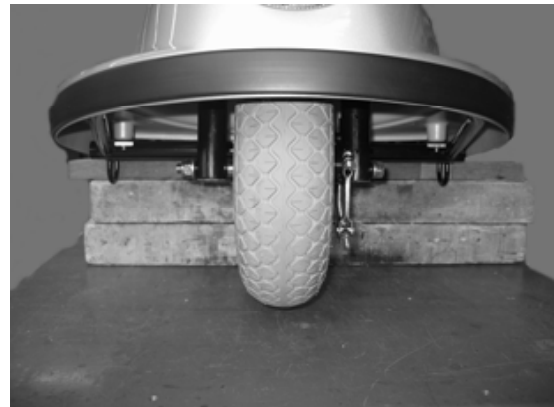

Replacing steering column:

- Remove drive lever screws (3).
- Remove drive lever (2).
- Unscrew the bolts (1) on the drive console.
- Remove drive console.

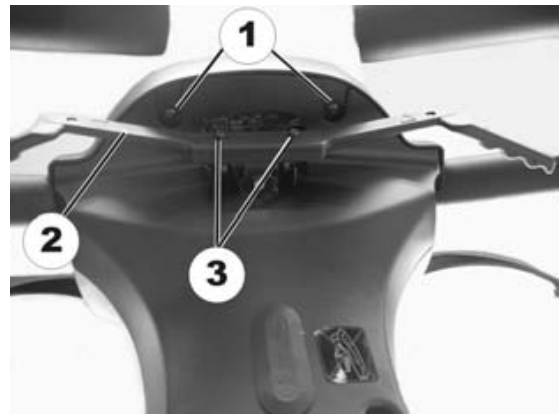

- Remove screws (1) on rear steering column cladding.
- Remove steering column cladding.

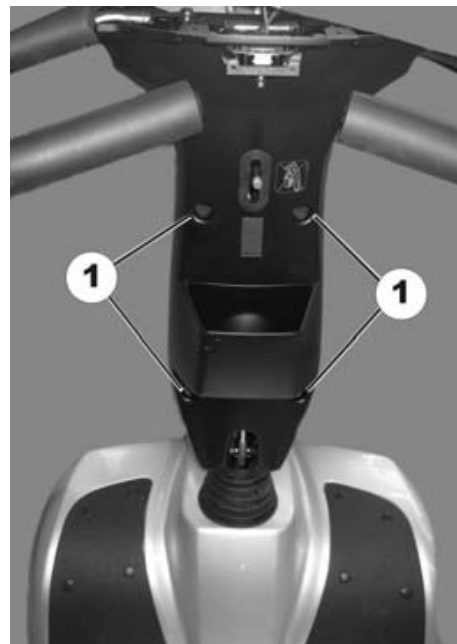

- Loosen screws on front basket holder.
- Remove basket holder.
- Remove spacer bushes.

- Disconnect cable (1, 2) from wiring harness.
- Remove screws (3) on front steering column cladding.
- Remove the front steering column cladding.

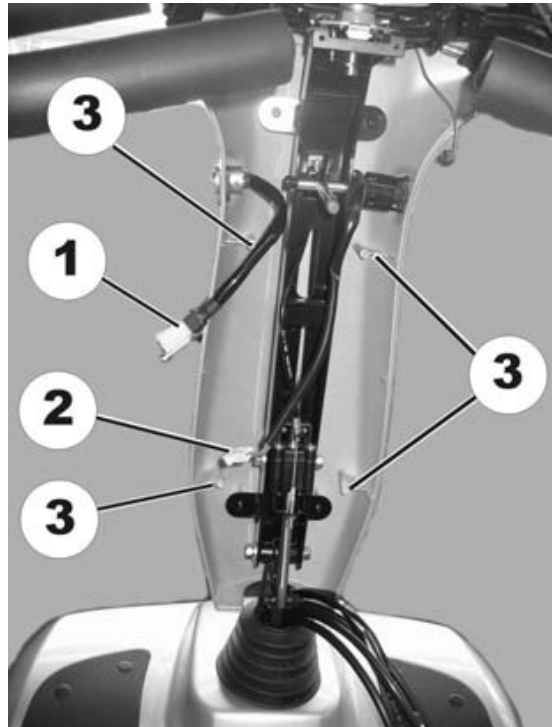

- Loosen the brake cable. (see chapter entitled "**Replacing brakes**" on page 34).
- Unscrew screw at clamp (1).
- Unscrew fixing bolt for steering column and remove.
- Pull steering column out upwards.

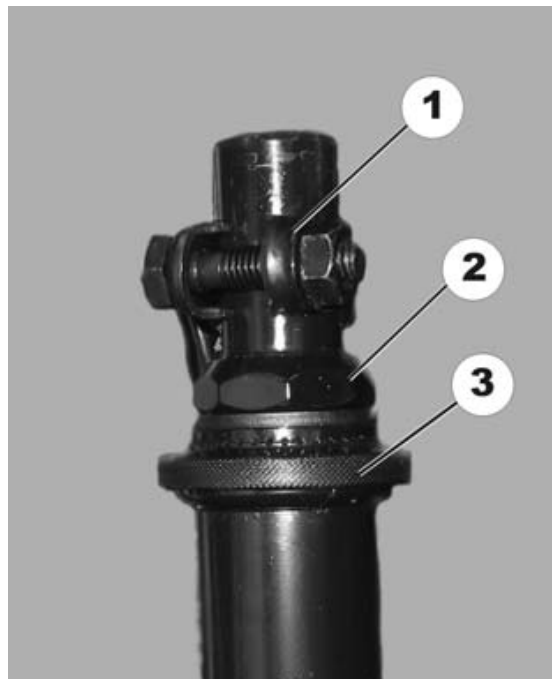

Replacing fork 3-wheel:

- Remove rubber mat in foot well.
- Loosen screws in chassis below mat.
- Remove chassis upwards.
- Dismantle front wheel (see chapter entitled "**Replacing front axle**" on page 28).

- Pull off clamp (1).
- Loosen fork bolt (2).
- Loosen knurled screw (3).
- Replace fork.

- Reassembly takes place in the reverse order.
- Operate brake and hold, tighten axle bolts at same time.
- Check functions (trial run).

7.7 Replacing brakes



ATTENTION! Risk of accident.

Accidental rolling can lead to accidents.

- *Secure the scooter against rolling away.*
-



NOTE:

When disassembling, note the position of small parts such as screws and washers. Put small parts down so that they can be reassembled in the right sequence.



NOTE:

The front axle can only be replaced on the 3-wheel version. The 4-wheel version does not have a replaceable axle.



Requirements:

- Open spanner, 12 mm.
 - Open spanner, 13 mm.
 - Philips screwdriver
 - Allen key 5 mm
 - Supporting wooden block
-
- Remove the seat.
 - Remove motor cover.
 - Separate battery cable.
-
- Place a supporting wooden block under the front part of the frame so that the front wheel is no longer touching the floor.

3-wheel version:

- Slacken brake cable (see chapter entitled "Replacing brake cable" on page 37).
- Disconnect the brake cable at the wheel (1).
- Remove screws (3) on spacer (2).
- Remove screws (6) on shock absorber (5).
- Loosen axle bolts (4) simultaneously on both sides.
- Pull front axle slowly out.

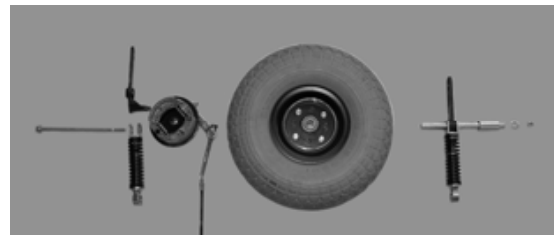
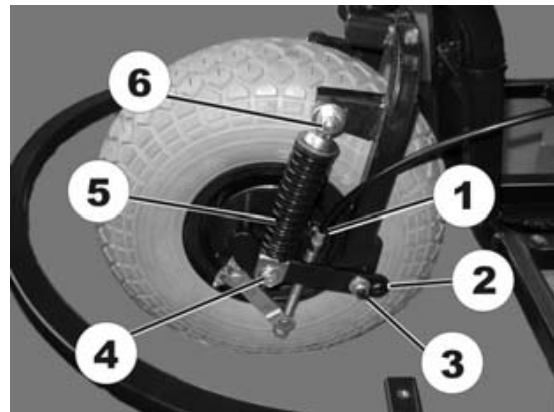

4-wheel version:

- Slacken both brake cables.
- Disconnect brake cable at affected wheel.
- Loosen wheel bolt.
- Pull wheel and brake off shaft.
- Pull brake out of brake drum.
- Replace brake lining or complete brake.



- Reassemble wheel and brake.
- Push wheel and brake onto shaft, or push axle through.
- Apply brake so that brake shoes can align.

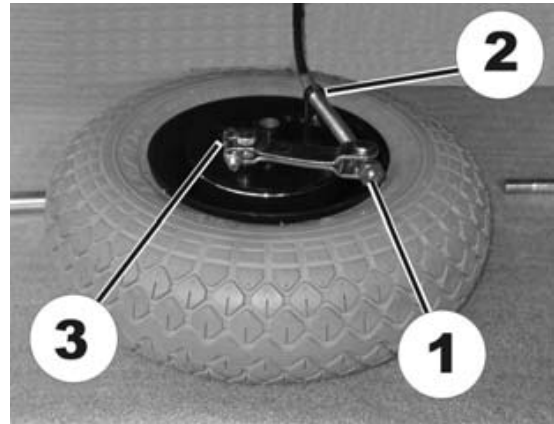

- Reassembly of the brake takes place in reverse order
- Adjust braking force on wheel using brake lever setting screw.
- Check braking function while pushing.

7.8 Replacing brake cable



ATTENTION! Risk of accident.

Accidental rolling can lead to accidents.

- *Secure the scooter against rolling away.*



NOTE:

When disassembling, note the position of small parts such as screws and washers. Put small parts down so that they can be reassembled in the right sequence.



Requirements:

- Open spanner, 10 mm.
- Phillips screwdriver

- Decrease the brake tension on the wheel using the setting screw (1).
- Disconnect the brake cable at the wheel (2).
- Disconnect brake cable at steering wheel brake lever.
- Route the brake cable through the cladding.
- Loosen brake lever screw (3) at wheel.
- Replace brake cable.

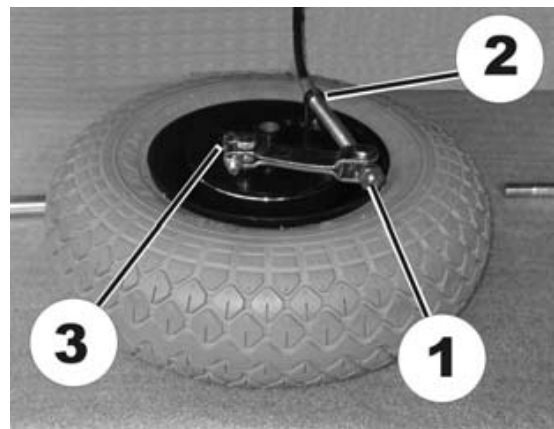

- Reassembly of the brake cable takes place in reverse order.
- Check braking function while pushing.

7.9 Replacing lifter/lifter electronic



ATTENTION! Risk of accident.

Accidental rolling can lead to accidents.

- *Secure the scooter against rolling away.*



NOTE:

When disassembling, note the position of small parts such as screws and washers. Put small parts down so that they can be reassembled in the right sequence.



Requirements:

- Open spanner, 14 mm.
- Phillips screwdriver

- Secure the scooter against rolling away.
- Remove the seat.
- Remove motor cover.
- Disconnect both battery plugs (1).

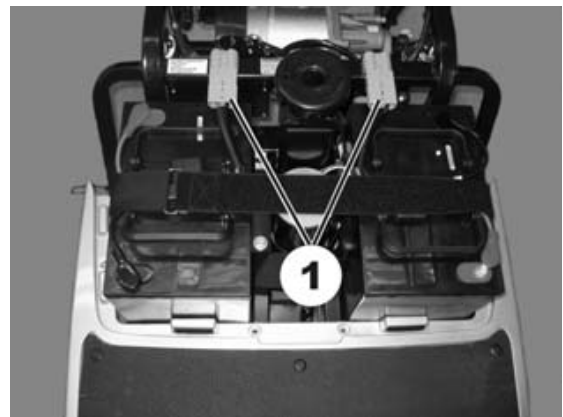

Replacing lifter:

- Remove batteries.
- Disconnect lifter cable at wiring harness connecting plug in motor enclosure.
- Remove screws (1) on lifter (2).
- Replace lifter.

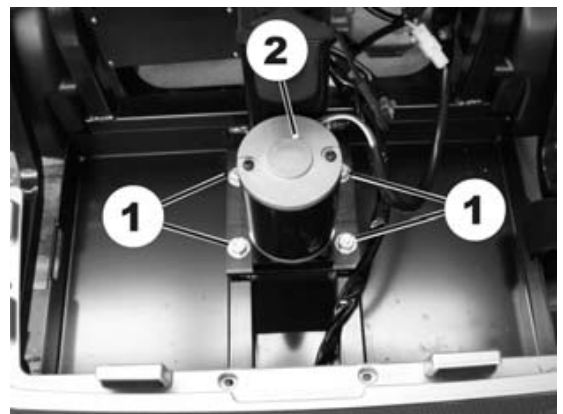

Replacing lifter electronic:

- Remove both screws (1) from the lifter electronic (2).
- Replace lifter electronic (2).

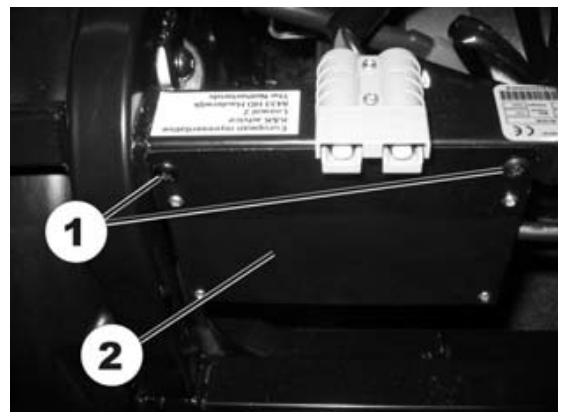

Replacing fuses in lifter electronic:

- Unscrew lifter electronic cover.
- Replace fuse (1).

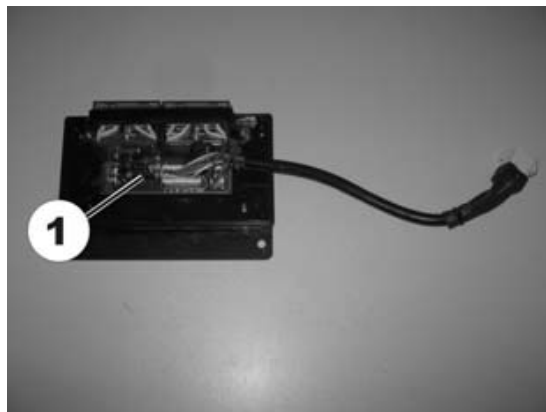

- Reassembly takes place in the reverse order.
- Check function

7.10 Replacing steering linkage/steering rod



ATTENTION! Risk of accident.

Accidental rolling can lead to accidents.

- *Secure the scooter against rolling away.*



NOTE:

When disassembling, note the position of small parts such as screws and washers. Put small parts down so that they can be reassembled in the right sequence.



Requirements:

- Open spanner, 10 mm.
 - Open spanner, 12 mm.
 - Open spanner, 13 mm.
 - Phillips screwdriver
 - Circlip pliers
 - Supporting wooden block
-
- Remove the seat.
 - Remove motor cover.
 - Disconnect battery cable (1).

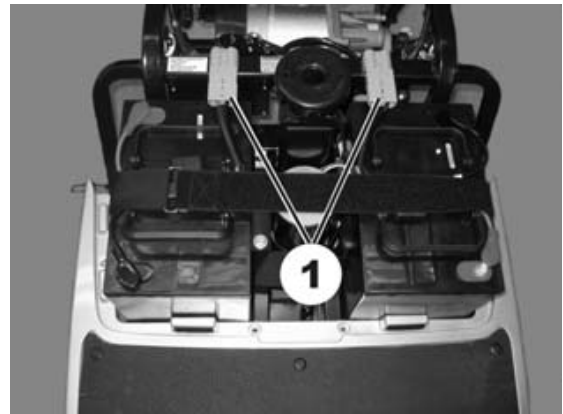

- Dismantle the steering column and the chassis (see chapter entitled "**Replacing steering column/fork 3-wheel**" on page 30).

Replacing steering link:

- Remove circlip (1) on steering link (2).
- Replace steering link.
- Adjust length of steering link using setting screws (3).

Replacing steering rod:

- Remove circlip (4) on steering rod (5).
- Replace steering rod.
- Adjust tracking by 1° inwards using setting screw (6). (See sketch).

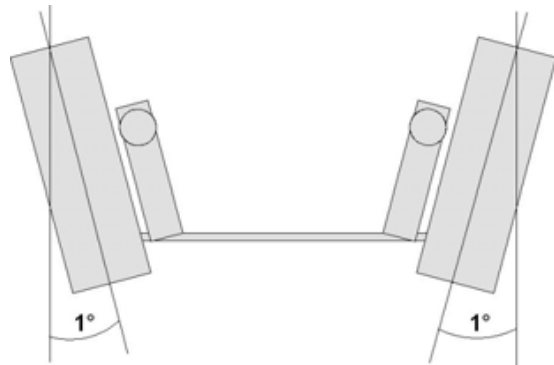
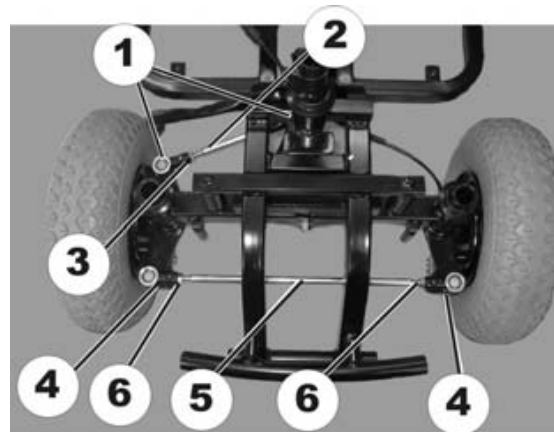

- Reassembly of the steering linkage and/or steering rod takes place in reverse order.
- Check function (trial run).

7.11 Replacing the seat suspension / spring



ATTENTION! Risk of accident.

Accidental rolling can lead to accidents.

- *Secure the scooter against rolling away.*



Note:

When disassembling, note the position of small parts such as screws and washers. Put small parts down so that they can be reassembled in the right sequence.



Note

The following seat support tubes are available for the seat suspension:

User weight	Length of the seat support tube	Part number
0 – 136 kg	508,5 mm	SP1528986
	533,5 mm	SP1528987
	558,5 mm	SP1528988
136 – 160 kg	508,5 mm	SP1522459
	533,5 mm	SP1522460
	558,5 mm	SP1522461



Requirements:

- 2 open spanners, 17 mm

- Secure the scooter against rolling away.
- Remove the seat.
- Loosen the securing bolt of the seat support tube.

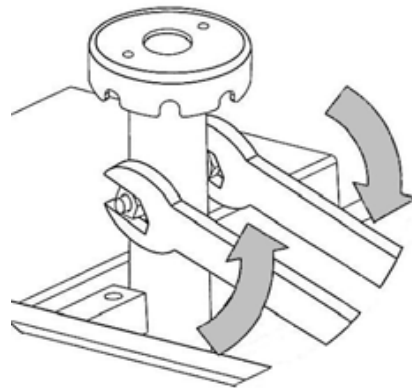

- Remove the bolt (7), nut and washers.
- Remove the seat support tube (2) from the receptacle tube (1).
- Remove the concertina type cover (3) including the spring (5) and the plastic end pieces (4 and 6).
- Fit the plastic end pieces (4 and 6) to the new spring.
- Grease the spring generously. The spring should be covered completely.
- Assemble the concertina type cover (3).
- Install the concertina type cover (3) including the spring (5) and the plastic end pieces (4 and 6).
- Insert the seat support tube (2) into the receptacle tube (1) and press down gently.
- Reposition the bolt (7), nut and washers.
- Firmly tighten the seat support bolt.
- Reposition the seat.

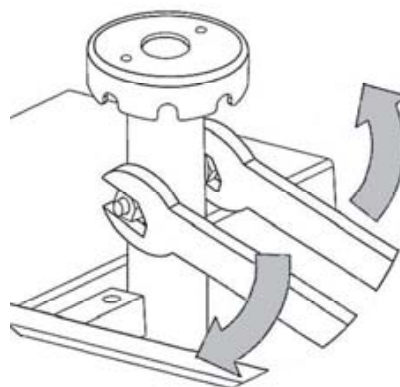
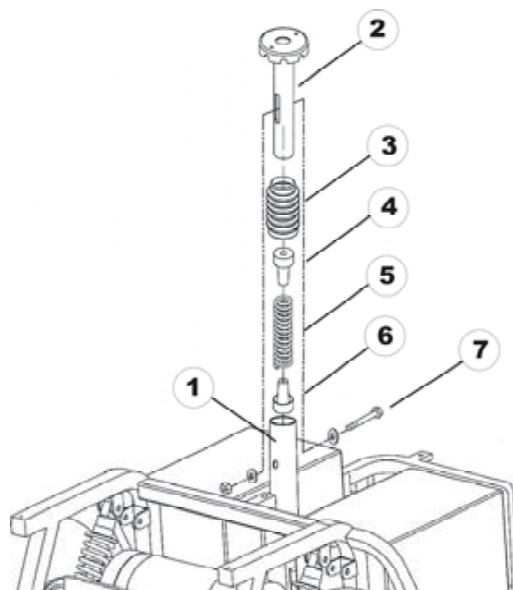

7.12 Replacing operating console



ATTENTION!

Burn and scald hazard if power cable is short-circuited!

- Turn off the power completely before removing any power supply components of the electric vehicle! Therefore take out the batteries.
- Avoid a bridging of the contacts during measurements on live electrical components!



NOTE:

The plugs on the operating console cannot be wrongly connected because all plugs have a different size and only fit in one socket.



Requirements:

- Phillips screwdriver

- Remove the seat.
- Remove motor cover.
- Disconnect battery cable (1).

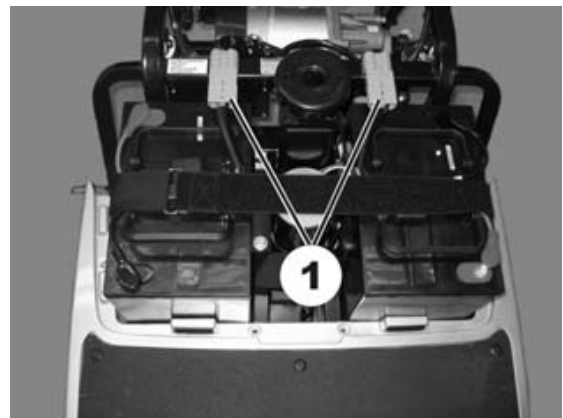

- Remove screws (1) below operating console.
- Remove operating console and fold upwards.
- Remove screws (3) on drive lever (2) and remove drive lever.

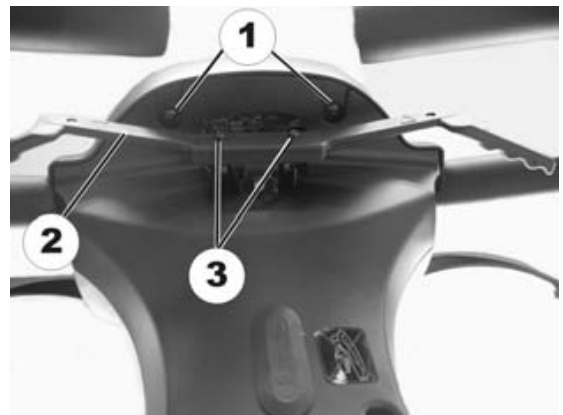

- Disconnect plug from operating console circuit board.
- Replace operating console.
- Reconnect plug with circuit board on new operating console.

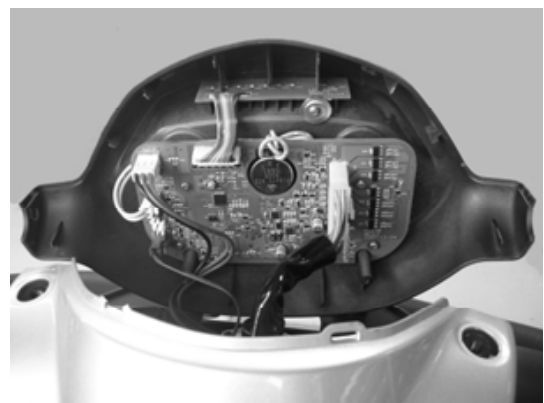

- Reassembly of the operating console takes place in reverse order
- Check all functions (trial run).

7.13 Replacing bend speed reducer



ATTENTION! Risk of accident.

Accidental rolling can lead to accidents.

- *Secure the scooter against rolling away.*



NOTE:

When disassembling, note the position of small parts such as screws and washers. Put small parts down so that they can be reassembled in the right sequence.



Requirements:

- Phillips screwdriver
 - Open spanner, 32 mm.
-
- Remove the seat.
 - Remove motor cover.
 - Separate battery cable.
-
- Remove front and rear steering column cladding, steering column and housing (see chapter entitled "**Replacing steering column/fork 3-wheel**" on page 30).

Replacing sensors (5) without mounting:

- Loosen screws.
- Replace sensor.

Replacing sensors (5) with mounting:

- Loosen fork bolt (1).
- Replace sensors (5) with mounting.

Replacing regulating unit (4):

- Loosen screws.
- Remove sensor (5).
- Loosen screws (3).
- Replace regulating unit (4).

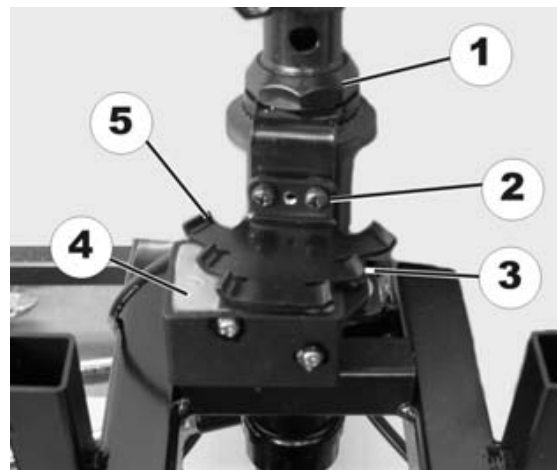

Adjusting:

- Set steering to straight ahead.
- Align sensor straight using regulating unit.
- Take hold of the sensor and tighten the fork screw.

Check:

- Turn the steering completely to the right and then the left.
- When the steering is turned to its limit, the 3 regulating unit switches should be visible.

- Reassembly takes place in the reverse order.
- Check functions (trial run).

7.14 Replacing the potentiometer



ATTENTION!

Burn and scald hazard if power cable is short-circuited!

- Turn off the power completely before removing any power supply components of the electric vehicle! Therefore take out the batteries.
- Avoid a bridging of the contacts during measurements on live electrical components!



ATTENTION! Risk of accident.

Wrong potentiometer setting can result in dangerous driving situations!

- Set the new potentiometer to the middle position before inserting.



Requirements:

- Phillips screwdriver
- Digital multimeter
- Allen key 2m

- Remove the seat.
- Remove motor cover.
- Disconnect battery cable (1).

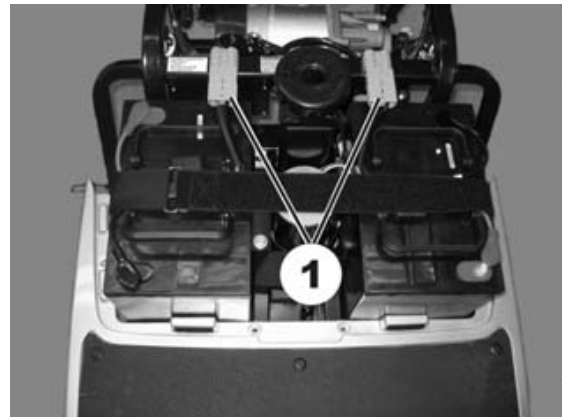

- Remove screws (1) below operating console.
- Remove operating console and fold upwards.
- Remove screws (3) on drive lever (2) and remove drive lever.

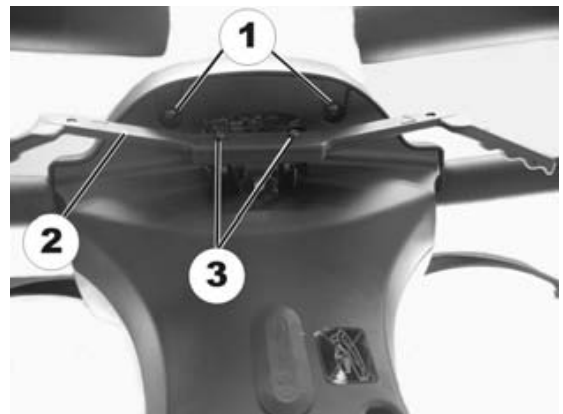

- Disconnect potentiometer plug (1) from the operating console.

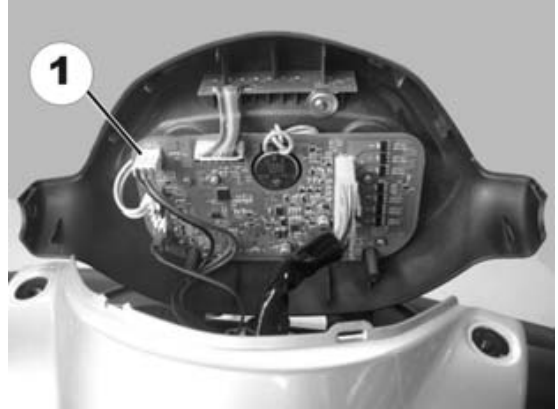

- Remove screws (1) on potentiometer.
- Replace potentiometer

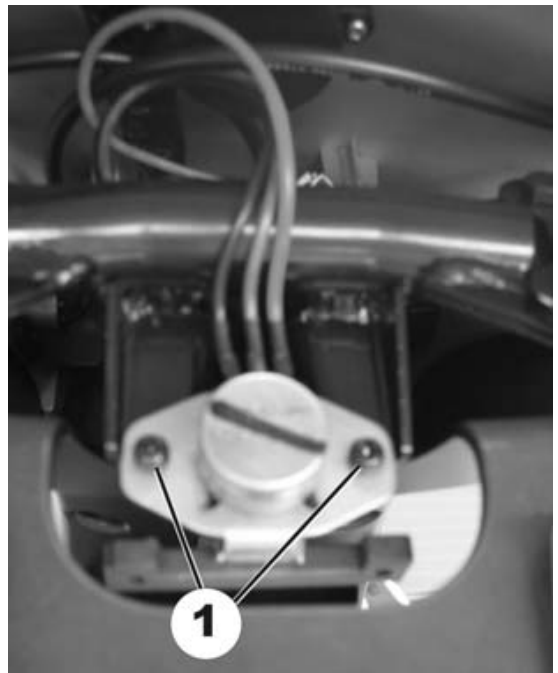

- Reconnect potentiometer plug (1) with operating console.

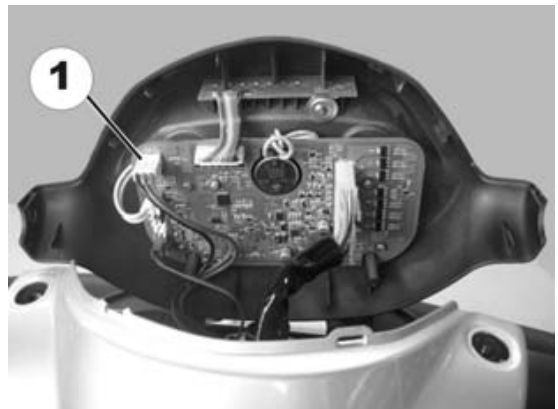

Setting the potentiometer to the middle position:

- Loosen the bolts (1) on the drive lever mounting.
- Twist the potentiometer shaft (2) until the same resistance (approx. 5kOhm) is measured between the central connection cable (3) and both outputs (4).
- Retighten the bolts on the drive lever mounting.
- Check settings and repeat the adjustment if necessary.

- Reassembly of the operating console takes place in reverse order
- Check all functions (trial run).

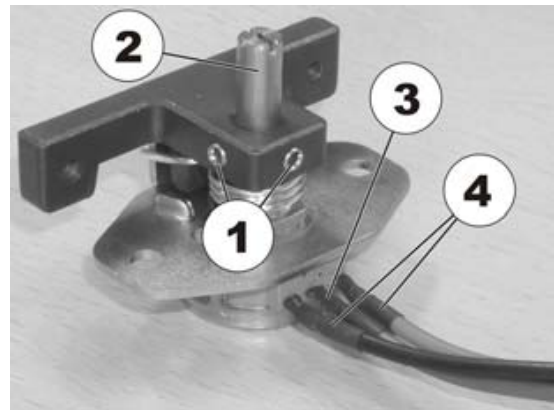

7.15 Replacing front headlight (lamp)



NOTE:

You can replace the headlight without removing the chassis. If, however, the working space is too small, you can remove the chassis as described in chapter entitled "**Replacing steering column/fork 3-wheel**" on page 30.



Requirements:

- Phillips screwdriver

- Remove the seat.
- Remove motor cover.
- Disconnect battery cable (1).



- Remove rear steering column cladding (see chapter entitled "**Replacing steering column/fork 3-wheel**" on page 30).

3-wheel version

- Remove screw (1) on front headlight under front cladding.
- Disconnect direction indicator cable (2) at wiring harness behind steering column cladding.



4-wheel version

- Remove screws (1) on front headlight under front cladding.
- Disconnect direction indicator cable (2) at wiring harness behind steering column cladding.

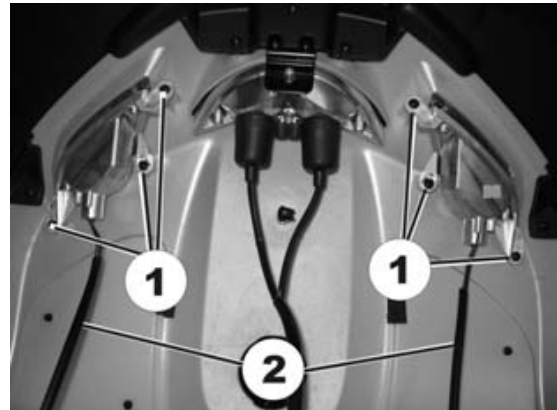

- Remove headlight.
- Remove screws (1) on headlight glass.
- Remove headlight glass.
- Replace bulb (2) in headlight.

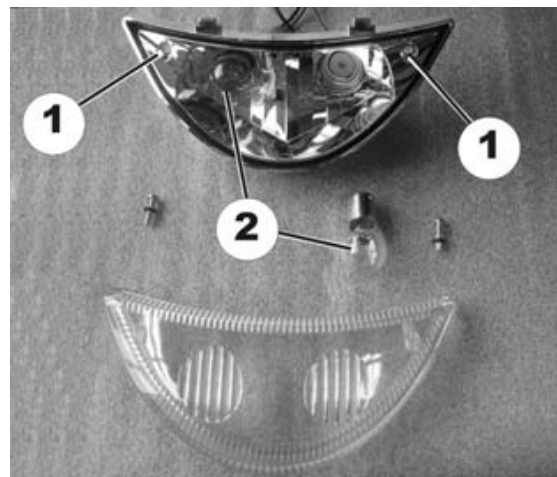

- Reassembly of the headlight takes place in reverse order.
- Check function

7.16 Replacing the front direction indicators



Requirements:

- Phillips screwdriver.

- Remove the seat.
- Remove motor cover.
- Separate battery cable.

3-wheel version

- Remove direction indicator screw (1).
- Disconnect direction indicator cable (2) from wiring harness.
- Replace direction indicator.
- Reassembly of the direction indicators takes place in reverse order
- Check functions.

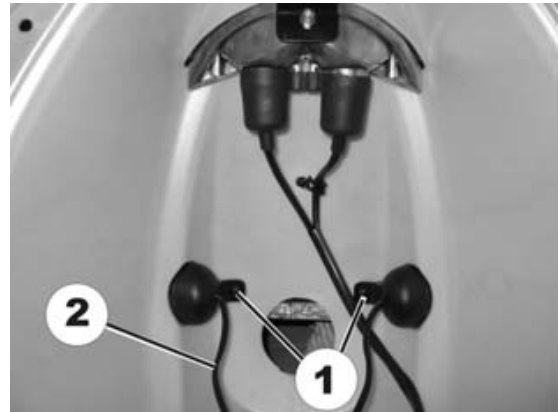

4-wheel version

- Remove direction indicator screw (1) on housing.
- Disconnect direction indicator cable (2) from wiring harness.
- Remove screws (3) on indicator glass.
- Remove indicator glass.
- Loosen screws (4) on orange-coloured cap (5) and remove cap.
- Replace lightbulb.
- Reassembly of the direction indicators takes place in reverse order
- Check functions.

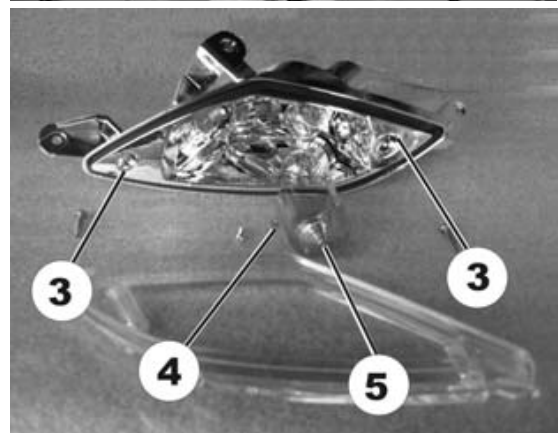
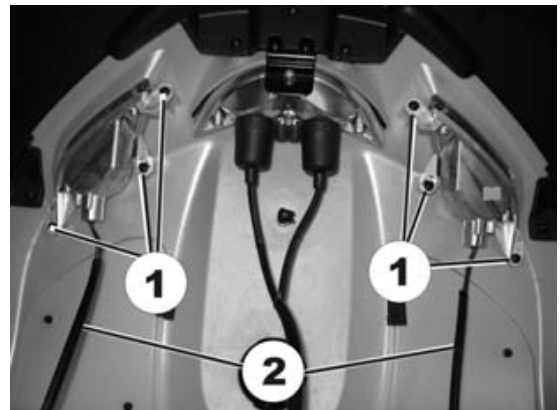

7.17 Replacing centre brake light



ATTENTION!

Burn and scald hazard if power cable is short-circuited!

- Turn off the power completely before removing any power supply components of the electric vehicle! Therefore take out the batteries.
- Avoid a bridging of the contacts during measurements on live electrical components!



NOTE:

When disassembling, note the position of small parts such as screws and washers. Put small parts down so that they can be reassembled in the right sequence.



Requirements:

- Phillips screwdriver

- Remove the seat.
- Remove motor cover.
- Disconnect both battery plugs (1).

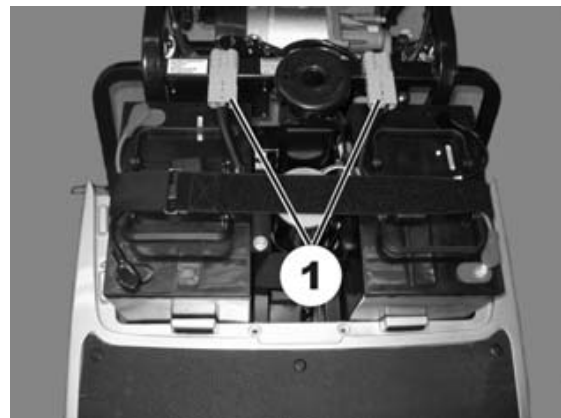

- Disconnect the plug (4).

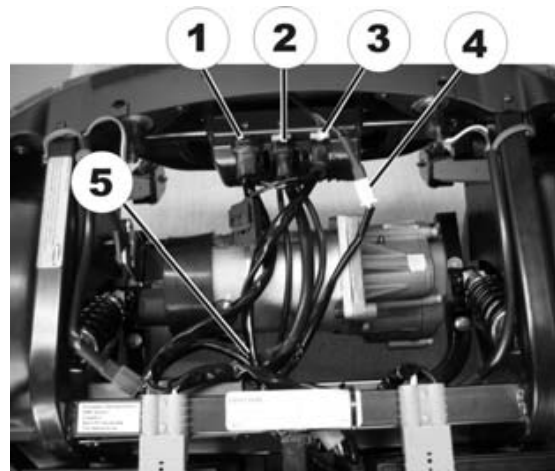

- Remove the bolt (1) on the rear panelling.

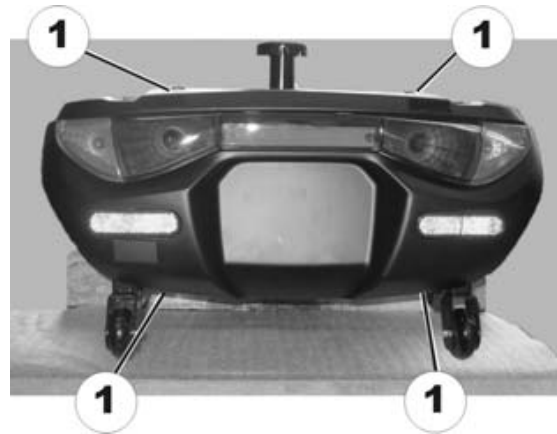

- Lift the rear panelling upwards.
- Remove screws (1) on brake light.
- Replace brake light.



- Reassembly of the brake light takes place in reverse order.
- Check functions (trial run).

7.18 Replacing rear lights/direction indicators



ATTENTION!

Burn and scald hazard if power cable is short-circuited!

- Turn off the power completely before removing any power supply components of the electric vehicle! Therefore take out the batteries.
- Avoid a bridging of the contacts during measurements on live electrical components!



NOTE:

When disassembling, note the position of small parts such as screws and washers. Put small parts down so that they can be reassembled in the right sequence.



Requirements:

- Phillips screwdriver

- Remove the seat.
- Remove motor cover.
- Disconnect both battery plugs (1).

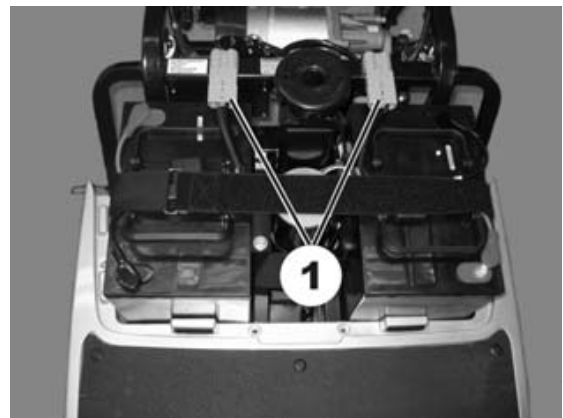

- Remove the bolt (1) on the rear panelling.

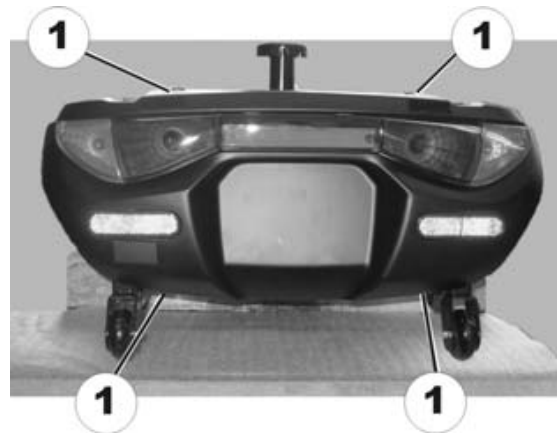

- Lift the rear panelling upwards.
- Remove screws (1) on rear light.



- Remove rear light.
- Remove screws (1) on rear light glass.

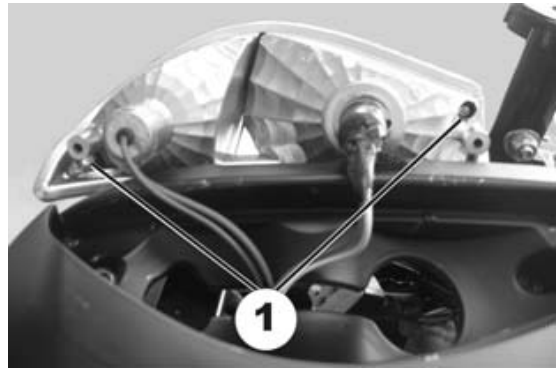

- Remove rear light glass (1).
- Replace lightbulbs (2).

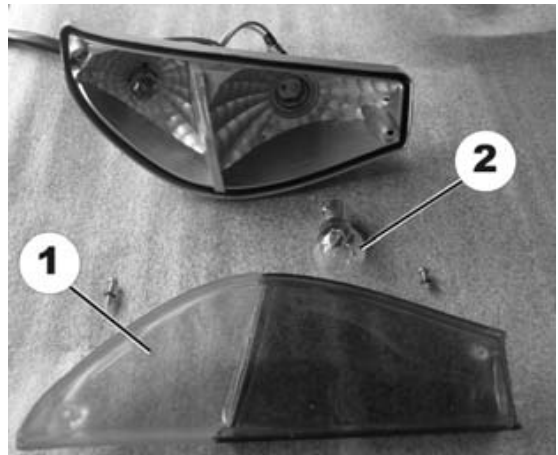

- Reassembly of the rear light/direction indicator takes place in reverse order.
- Check function

7.19 Replacing the electronic module



ATTENTION! Risk of accident.

When parking the scooter on the scooters support wheels it is no longer slowed by the engine brake. The scooter can roll away out of control.

- Place the scooter rear frame on a supporting wooden block before you remove the wheels.



ATTENTION!

Burn and scald hazard if power cable is short-circuited!

- Turn off the power completely before removing any power supply components of the electric vehicle! Therefore take out the batteries.
- Avoid a bridging of the contacts during measurements on live electrical components!



WARNING!

Any changes to the drive program can affect the driving characteristics and the tipping stability of the mobility aid!

- Changes to the drive program may only be carried out by trained Invacare® specialist dealers!
- Invacare® can only give a warranty for safe mobility aid driving behaviour - especially tipping stability - for unaltered standard drive programs!



ATTENTION! Risk of accident.

Accidental rolling can lead to accidents.

- Secure the scooter against rolling away.



Note:

The electronic system is supplied with a standard drive program. If you have carried out customer-specific modifications to the drive program, you will have to make these changes again after installing the new electronic module.



Note:

When disassembling, note the position of small parts such as screws and washers. Put small parts down so that they can be reassembled in the right sequence.



Note:

The plugs on the electronic module cannot be wrongly connected because all plugs have a different size and only fit in one socket.



Requirements:

- Open spanner, 10 mm.
- Open spanner, 17 mm.
- Rubber hammer
- Phillips screwdriver
- Supporting wooden block
- To adapt the drive program: programming software or hand programming device and electronic system installation manual, available from Invacare®.

- Secure the scooter against rolling away.
- Place supporting wooden block under the frames at battery holder height.
- Remove the seat.
- Remove motor cover.
- Disconnect both battery plugs (1).

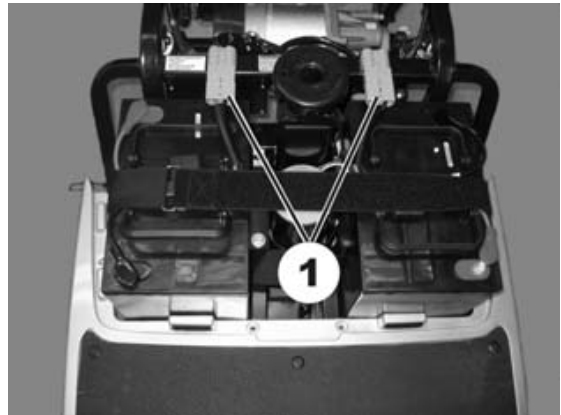

From the operating manual:

- Unscrew the rear wheel fixing bolts.
- Remove rear wheels.

- Remove the drive unit (see chapter entitled "**Replacing the drive motor**" on page 20).

- Remove screws (1) on electronic module.

Rhino1:
DS112KB02
DS162KD01

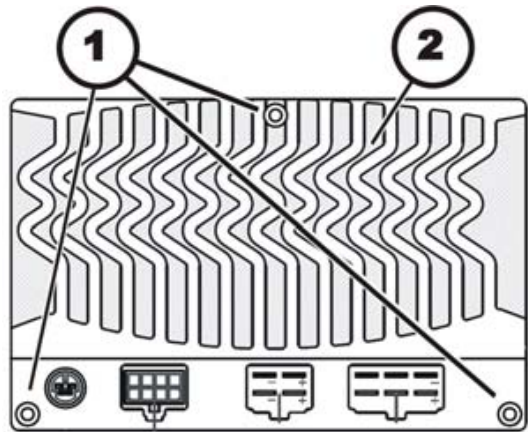

Rhino 2:
DS120:

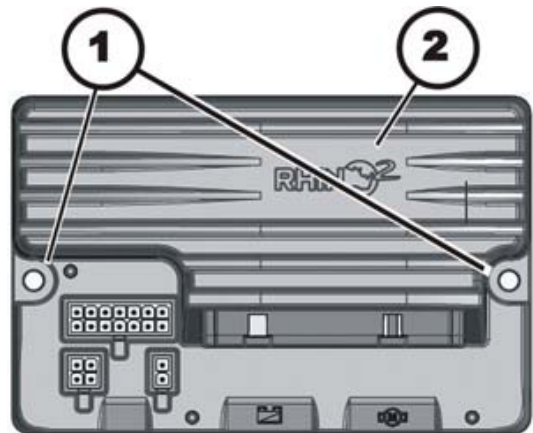

DS160:

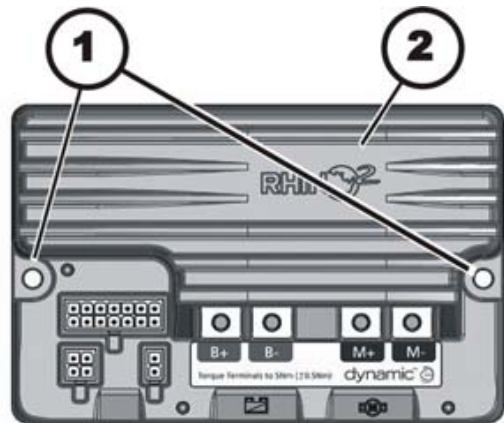

- Replace electronic module (2).

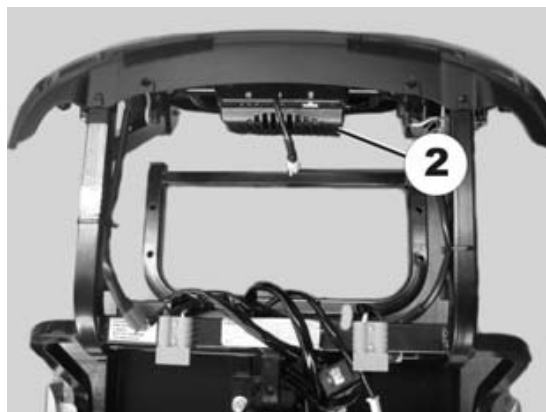

- Reassembly of the drive and the electronic module takes place in reverse order.
- Load drive program onto electronic module. See electronic software description.
- Check all functions (trial run).

7.20 Updating software

Invacare is continuously carrying out further development and improvements to drive programs for electric vehicles. For this reason, you should always check whether the drive program version number is up-to-date when carrying out any repairs or regular maintenance. If a newer version is available, the drive program must be updated. The procedure for updating the drive program is described in the wizard software operating manual.

**NOTE:**

The electronic system is supplied with a standard drive program. If you have carried out customer-specific modifications to the drive program, you will have to make these changes again after installing the new electronic module.

**WARNING!**

Any changes to the drive program can affect the driving characteristics and the tipping stability of the mobility aid!

- *Changes to the drive program may only be carried out by trained Invacare® specialist dealers!*
 - *Invacare® can only give a warranty for safe mobility aid driving behaviour - especially tipping stability - for unaltered standard drive programs!*
-

**Requirements:**

- Dynamic® Wizard software
 - Operating manual for Wizard software
 - For further information on other requirements - such as the minimum system configuration of the PC to be used for programming, necessary programming cables - see the user manual of the Wizard software. You find the latest version of the user manual in the download area on <http://www.dynamiccontrols.com/>.
-